

Electronics II

Wien Oscillator

P. Stallinga

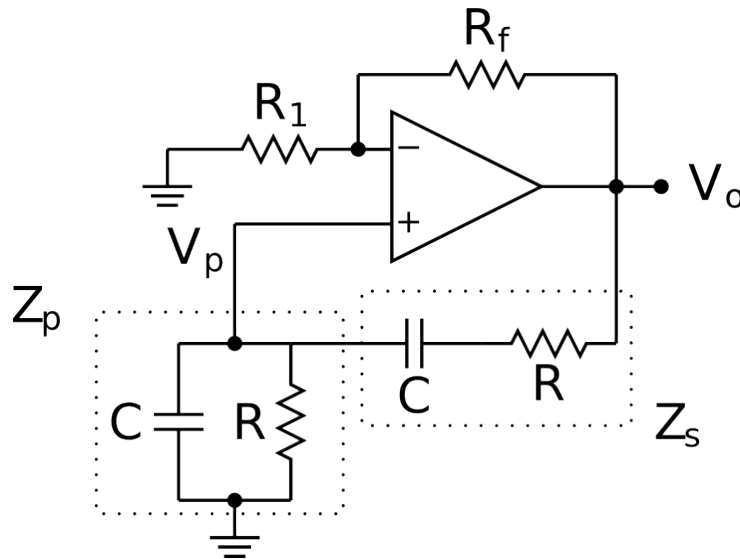

The above circuit is a Wien Oscillator. It consists of an ideal opamp with negative feedback composed of R_1 and R_2 , and a branch with positive feedback, composed of two RC networks.

- What is the gain A of the circuit composed of the opamp and the two resistors R_1 and R_2 ? Consider the input at the + terminal.
- Analyze the circuit and determine the Barkhausen Criterion for oscillation.
- Give values for the components to get a pure sinusoidal oscillation at 10 kHz.